

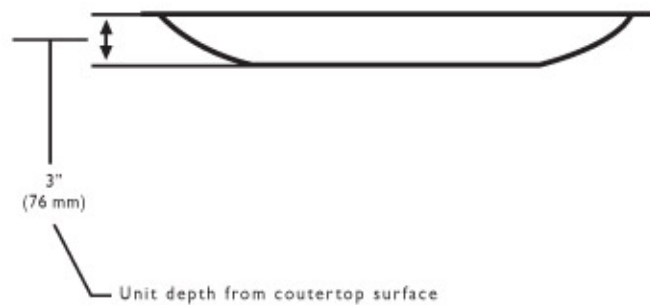

6982 S Quentin St  
Centennial, CO 80112

# COUNTERTOP RECESSED MOUNTED BABY CHANGING STATION

# KB112-01RE

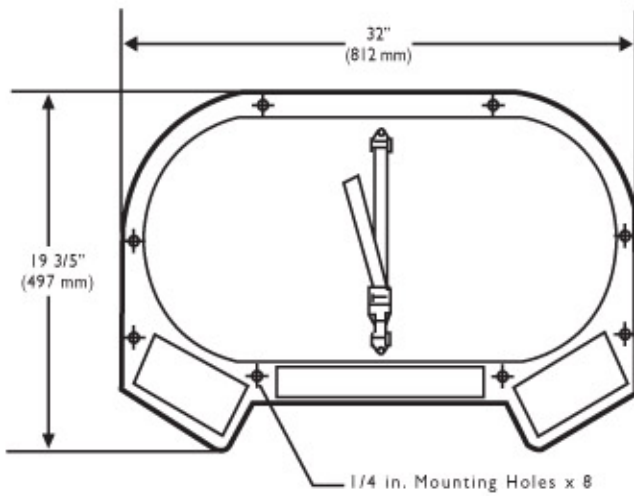

Continued...

**MATERIALS:**

FDA approved thermoformed high-density polyethylene. Mounting instructions and hardware included. Contoured changing surface is 379.04 sq. in. (244,541.45 sq. mm) and comes complete with nylon safety straps.

**OPERATION:**

For use in restrooms where counter space is more abundant than wall space. High-density polyethylene has no sharp corners, is easy to clean and resists odors and bacterial growth.

**Warning:** To ensure that the unit supports the intended loads, baby changing stations must be properly installed according to the manufacturer's instructions

**INSTALLATION:**

To ensure proper installation and compliance with building codes, it is recommended that a qualified person or carpenter perform the installation of the unit.

**Drilling holes and mounting the station:**

1. Remove the station from the shipping container and check for any freight damage.
2. Remove the rough opening template from the shipping carton. Separate the oval template from the cardboard sheet. Use template to trace rough opening to allow saw access. Cut out rough opening.
3. Construct under counter support as shown in the illustration. Support should be 3" below bottom of mounting surface.
4. Place unit onto counter surface in desired position. Using the unit's mounting holes as a guide, mark the screw hole locations with a pencil. Remove unit and drill holes with a 5/32" (3.97 mm) diameter drill bit. Drill down 3/4" (19.05 mm) deep. Place the unit onto counter surface using the drilled holes as a guide. Screw fasteners through holes into countertop surface. Apply a suitable water sealant (not provided) such as silicone around the base of the unit.
5. Fill the built-in dispenser with sanitary bed liners. Replacement parts and additional liners can be purchased from your local distributor.

**Caution:**

Drill carefully through ceramic tile and other hard counter top materials.

**SPECIFICATION:**

Baby changing station shall be durable, high impact polyethylene body. Design of unit shall be counter recessed mounted. Bed shall have smooth concave changing area with a nylon safety strap and universal instruction graphics. The unit shall be backed by a 5-year manufacturer's limited warranty. Unit shall be manufactured in the U.S.A.

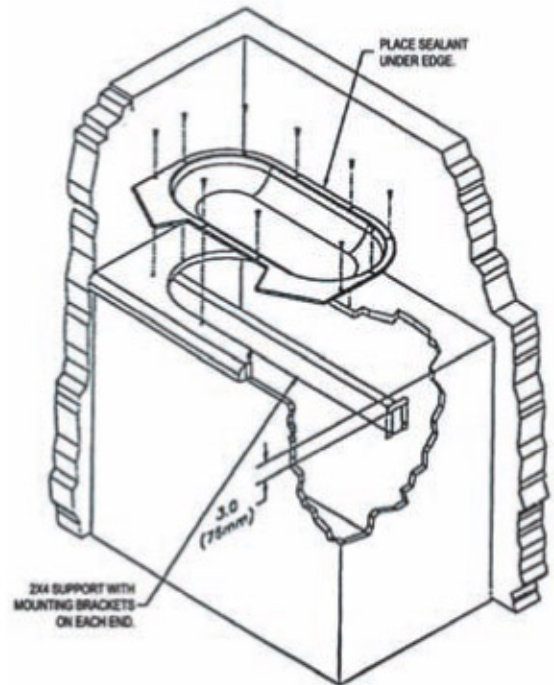

**Distributed by**  
**www.Ameraproducts.com**  
**Phone: (800) 608-6568**  
**Fax: (409) 840-5545**  
**info@ameraproducts.com**

The illustrations and descriptions herein are applicable to production as of the date of this Technical Data Sheet.

The manufacturer reserves the right to, and does from time to time, make changes and improvements in designs and dimensions without notice.

